

SealBoss®

HP100 Hand Pump



Product Data Sheet

Reliable, Professional Grade Injection Hand Pump

SealBoss® HP100 Hand Pump

- Every Day Use
- Lightweight
- Injection Pressure > 1500 PSI
- Easy to use, clean & maintain for long term use
- Single component
- Pressure gauge
- Mounted on stand, draws material from container or bucket
- Compatible with most SealBoss® injection grouts including epoxy resins, packers and couplers



Hose set sold separately

Technical Data

Max pressure:	> 1500 psi
Weight:	25 lbs
Single component:	steel ball valve, one o-ring

The SealBoss® HP100 Pump is a powerful and versatile injection hand pump for the complete line of our injection grouts. Suitable for smaller jobs and as an inexpensive back-up system. Very reliable and easy to maintain.

Pump includes stand & pressure gauge. Pressure hose, shut-off valve and zerk coupler tip sold separately. Just place premixed resin next to pump or underneath and point suction tube into grout container. Piston can be pulled out for effective cleaning. Features a very compact design with integrated stand.

Parts can be replaced by the savvy contractor to keep downtime at an absolute minimum.

This injection pump can be used for most of the SealBoss® polyurethane and epoxy injection line products with viscosities between 10 and 1000 cps. Contact your SealBoss® technician to confirm that your product is suitable for use with this machine.

Parts List

1. Pump Lever
2. Short Lever
3. Piston
4. Piston O-Ring
5. Housing
6. Gauge Connector
7. Spring (2)
8. Ball (2)
9. Vent Valve
10. In-Out Valve Housing
11. Valve / Suction Hose Connector
12. Gauge
13. Lever Bolt Short (2)
14. Lever Bolt Long

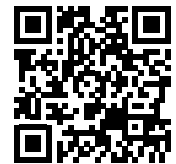
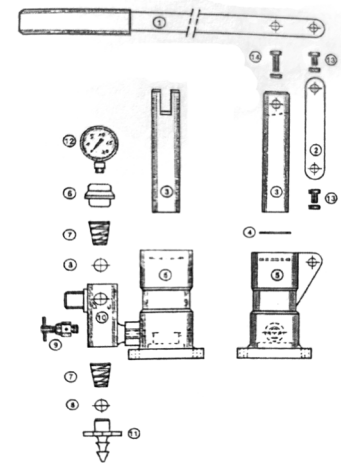

Limited Warranty Policy and Disclaimer for Products Supplied and/or Distributed by SealBoss Corp.: SealBoss Corp. Products are for Professional Use. All recommendations, statements and technical data herein are based on tests we believe to be reliable and correct, but accuracy and completeness of said tests are not guaranteed and are not to be construed as a warranty either expressed or implied. User shall rely on his or her own information and tests to determine suitability of the product for the intended use and user assumes all risk and liability resulting from his or her use of the product. Nothing contained in any supplied materials relieves the user of the obligation to read and follow the warnings and instruction for each product as set forth in the current Technical Data Sheet, product label and Safety Data Sheet prior to product use. SealBoss Corp. warrants supplied / distributed products to be free of manufacturing defects. Seller's and manufacturer's sole responsibility shall be to replace that portion of the product of the manufacturer which proves to be defective. There are no other warranties by SealBoss Corp. of any nature whatsoever expressed or implied, including any warranty of merchantability or fitness for a particular purpose in connection with this product. SealBoss Corp. shall not be liable for damages of any sort, including remote or consequential damages resulting from any claimed breach of any warranty whether expressed or implied. SealBoss Corp. shall not be responsible for use of this product in a manner to infringe on any patent or any other intellectual property rights held by others. In addition, no warranty or guarantee is being issued with respect to appearance, color, fading, chalking, staining, shrinkage, peeling, UV damage, excessive temperature exposure, normal wear and tear or improper application by the applicator. Damage caused by abuse, neglect and lack of proper maintenance, acts of nature and / or physical movement of the substrate or structural defects are also excluded from the limited warranty. SealBoss Corp. reserves the right to conduct performance tests on any material claimed to be defective prior to any repairs by owner, general contractor, or applicator. Neither seller nor manufacturer shall be liable to the buyer or any third person for any injury, loss or damage directly or indirectly resulting from use of or inability to use the product. Recommendations and statements other than those contained in a written agreement signed by an officer of the manufacturer shall not be binding upon the manufacturer or seller. SealBoss Corp. reserves the right to change the properties of products without notice.

Revised 201705